

Application Note

**Impulsive Noise
EMC Measurements
on Set-Top Boxes**

Products:

<i>TV Test Transmitter</i>	<i>R&S SFQ</i>
<i>TV Test Receiver</i>	<i>R&S EFA</i>
<i>I/Q Modulation Generator</i>	<i>R&S AMIQ</i>
<i>"DVB-T Bursted Noise Signal Generation"</i>	<i>Appl.Note 1MA51</i>

Contents

**Impulsive Noise
EMC Measurements on Set-Top Boxes**

1 Scenario 3

2 Residual carrier calibration for the above test setup 4

3 Example of an impulsive noise measurement 6

4 Conclusion 9

Impulsive Noise EMC Measurements on Set-Top Boxes

1 Scenario

You are sitting back relaxed in an armchair watching a broadcast of Mozart's Piano Concerto No. 21, played at the Vienna Opera House on New Year's Day. The second part is going to start soon, and it will be a pleasure for you to follow it on TV. The conductor is just giving the signs – and then suddenly there's nothing but a crackling noise and picture interference. Enjoying the music comes to an end.

What happened? Your son is making a milkshake with a non-screened kitchen blender. The sparks on the collector of the electric motor – also called impulsive noise – are impairing the TV reception. And you were so looking forward to the program, which with the help of your new digital set-top box (STB) with maximum picture and tone quality would have been wonderful to watch and listen to. Obviously, the STB wasn't tested for adherence to EMC requirements (EMC = electromagnetic compatibility) under these particular operating conditions, as a generator for simulating real interference wasn't available.

Rohde & Schwarz now offers a solution to this problem:

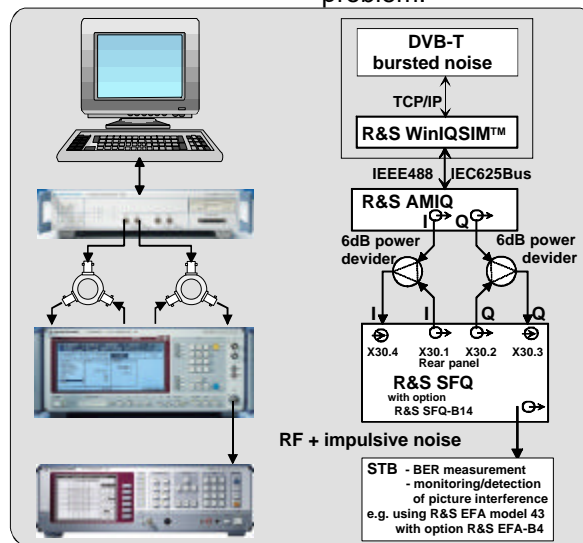

Fig. 1 Test setup

The simulation of impulsive noise for tests on set-top boxes for digital TV (DTV) has so far been a highly complex task regarding the reproducibility of test signals. Using state-of-the-art technology from Rohde & Schwarz, this task can be accomplished with a simple test setup

How to generate impulsive noise with a PC is described in Application Note 1MA51 "DVB-T Bursted Noise Signal Generation" on the R&S website. Using the I/Q Modulation Generator R&S AMIQ and the software described in the application note, any waveforms can be calculated and generated, including pulsed noise with variable amplitudes for the I and Q channels. The signal files generated on the PC are

transferred to the R&S AMIQ, where the impulsive noise is available in the form of baseband signals at the I/Q outputs.

The TV Test Transmitter R&S SFQ supplies I/Q baseband signals as well as modulated RF signals in accordance with the most important DTV standards, i.e. DVB-C, DVB-S, DVB-T and ITU-T J.83/B and ATSC 8VSB. The I/Q baseband signals from the R&S SFQ and the R&S AMIQ are combined via 6 dB power dividers and reapplied to the R&S SFQ via the rear I/Q output/input connectors (option R&S SFQ-B14), which must be fitted for this measurement. The 6 dB power divider is also known as 6 dB power splitter or 50 Ω delta connection.

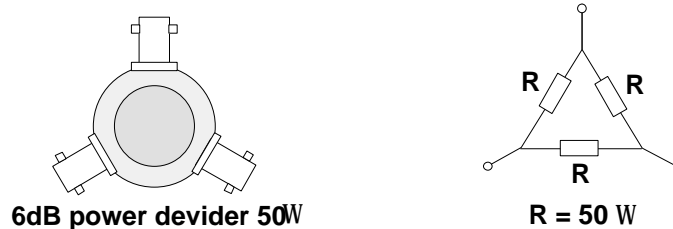

Fig. 2 50 Ω, 6 dB power divider; mechanical design and schematic diagram

Passive addition by means of the 6 dB power dividers reduces the I/Q signal level by 6 dB. This is outweighed, however, by the advantages of this approach, i.e. the simple method of interference simulation and the fact that there is no additional DC offset distorting the residual carrier of the DTV RF signal.

The R&S SFQ produces Gaussian white noise in the frequency range of interest (with Noise Generator option R&S SFQ-B5). This noise is added to the combined impulsive noise and I/Q baseband signals before the cumulative signal is applied to the I/Q modulator. The 6 dB attenuation introduced by the power dividers is not considered in the result, so 6 dB have to be subtracted from the NOISE value displayed on the R&S SFQ to obtain the correct result.

The bit error ratio (BER) is measured on the common interface (CI) (if available) of the set-top box or directly with the DVB-T Test Receiver R&S EFA model 40 or 43. The point at which non-correctable errors initially occur is found by increasing the interference signal level. This point is equivalent to a $BER > 2 \cdot 10^{-4}$ before Reed Solomon; this is the limit of reliable reception, which is to be determined by the impulsive noise measurement.

Another approach to finding this limit is by monitoring the TV picture and detecting when errors first occur in the decoded signal from the STB. If the STB under test does not include a CI, this is the only – although not reliably reproducible – approach.

2 Residual carrier calibration for the above test setup

including R&S DVB-T Test Receiver R&S EFA (model 40 or 43)

Residual carrier suppression is one of the main factors governing DVB-T signal quality. Residual carrier suppression is referenced to the signal power of a single carrier in the COFDM symbol; it will therefore scarcely exceed 20 dB. If, by contrast, residual carrier suppression is referenced to the total power in a DVB-T channel, the value obtained will be higher by 38.3 dB for 8k and by 32.3 dB for 2k. Residual carrier suppression is directly proportional to the DC offsets of the I and Q signals.

If the sum of the offsets of the I/Q outputs of the R&S SFQ and the R&S AMIQ is too large, i. e. if residual carrier suppression referenced to CW is not higher than 55 dB for the specific DTV standard, CARRIER SUPPRESSION on the R&S AMIQ can be aligned by alternately adjusting the I and the Q DC component until the required value is attained. The DVB-T Test Receiver R&S EFA (model 40 or 43) acts as a probe in this measurement.

Since appropriate residual carrier suppression is of paramount importance – ensuring good BER values before Viterbi in a DVB-T receiver, for example – a simple and effective method of how to accurately align this parameter will be presented here.

The DVB-T Bursted Noise (DVBTBN) software calculates the interference signal. The I/Q Simulation Software R&S WinIQSim™ checks the corresponding time-domain signal. The bursted noise signal is then transferred to the R&S AMIQ. The DVBTBN and the WinIQSim™ packages can be downloaded from the Rohde & Schwarz website. Prior to adjusting the I/Q DC components, the I/Q amplitudes of the bursted noise signal are set to zero on the R&S AMIQ by means of R&S WinIQSim™. A nominal DC voltage of 0 V is now present at the I/Q outputs. This allows the calibration of DC voltage offsets

inherent in the test setup by carrying out I/Q offset adjustment on the R&S AMIQ by means of R&S WiniQSim™. This is a precondition for the correct adjustment of carrier suppression in the modulator of the TV Test Transmitter R&S SFQ. For coarse adjustment of the carrier suppression, the DVB-T 2k mode is selected on the R&S SFQ,

and the constellation diagram of the central carrier (No. 852) is displayed on the Test Receiver R&S EFA. If the residual carrier suppression is incorrectly aligned, a constellation diagram similar to that shown in Fig. 3a will appear on the R&S EFA.

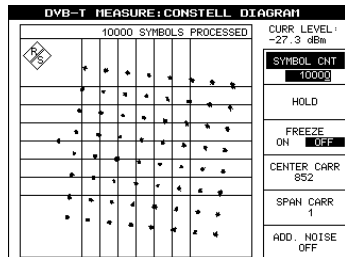

Fig. 3a Constellation diagram of central carrier in 2k mode prior to adjustment of residual carrier suppression.

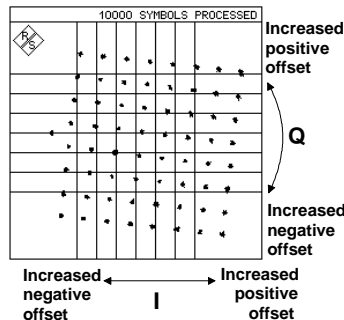

Fig. 3b Coarse adjustment is performed by rotating the constellation diagram (by varying the offset of the Q component) and by shifting the I/Q value pairs (by varying the offset of the I component).

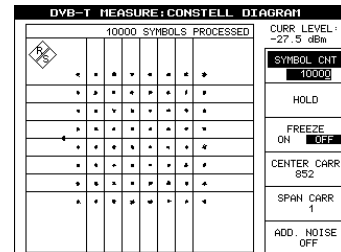

Fig. 3c Nearly correct constellation diagram of central carrier in 2k mode with coarsely adjusted residual carrier suppression.

The constellation diagram is rotated as shown in Fig. 3b so that the I/Q value pairs of the central carrier occur on horizontal lines (this is done by varying the offset of the Q component). In addition, the I/Q value pairs are shifted to the centers of the decision fields (by varying the offset of the I component). This yields a nearly correct constellation diagram as shown in Fig. 3c.

For fine adjustment, seven carriers around the central carrier (No. 3408 with 8k) are selected in the DVB-T 8k mode and mapped into a constellation diagram in addition to the central carrier. After coarse alignment of the residual carrier, a diagram similar to that of Fig. 4 is obtained.

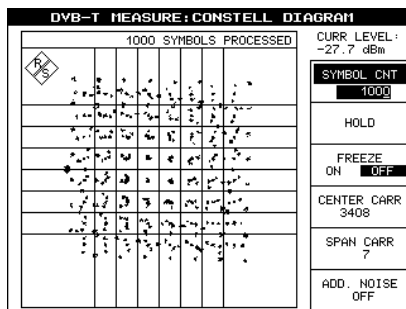

Fig. 4 Constellation diagram of 7 innermost carriers and central carrier in 8k mode.

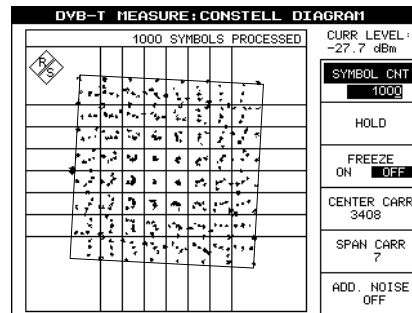

Fig. 5 Constellation diagram of Fig. 4 rotated clockwise.

In Fig. 5, parts of the constellation diagram of Fig. 4 are rotated clockwise; this rotation can be compensated by increasing the offset of the Q component in a positive direction on the R&S AMIQ. Parts rotated to the left would be compensated by increasing the Q offset in a negative direction. After this, a constellation diagram like that shown in Fig. 6 is obtained. If the outer conchoids of I/Q value pairs open to the

outside as shown in this figure, this faulty alignment will be compensated

by increasing the I offset in a negative direction. If, by contrast, the conchoids open to the inside (Fig. 7), increasing the I offset in a positive direction would rectify the error.

With optimally aligned I/Q offsets, a constellation diagram like that shown in Fig. 8 will appear. This alignment yields carrier suppression values >25 dB referenced to the power of a single carrier

in the COFDM symbol, or values $>(25 \text{ dB} + \text{signal power in the DVB-T channel} - 38.3 \text{ dB}) = 63.3 \text{ dB}$ (for 8k) referenced to the total

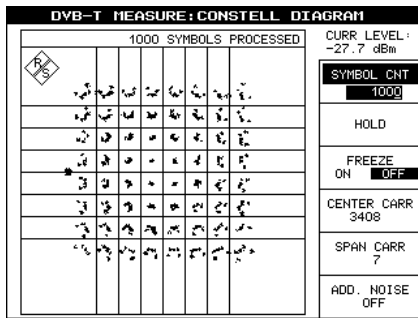

Fig. 6 Constellation diagram with corrected Q component offset. I component offset not yet optimized (conchoids of I/Q value pairs open to the outside).

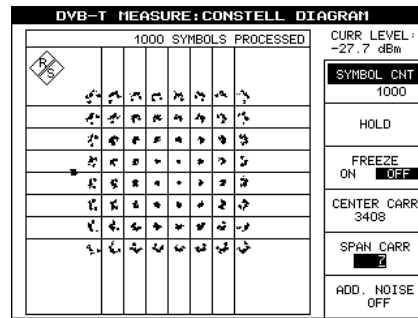

Fig. 7 Constellation diagram with corrected Q component offset. I component offset not yet optimized (conchoids of I/Q value pairs open to the inside).

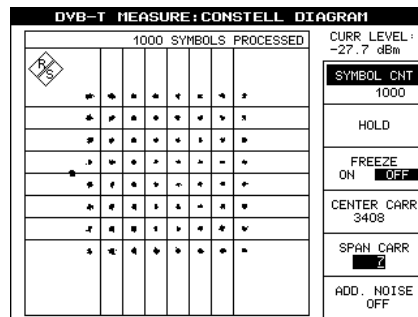

Fig. 8 Optimally aligned constellation diagram in 8k mode with residual carrier suppression $>25 \text{ dB}$.

In most cases, alignment in the 2k mode already produces CARRIER SUPPRESSION values $>25 \text{ dB}$. To verify correct alignment, however, residual carrier suppression has to be checked also in the 8k mode.

The test solution offered by Rohde & Schwarz also provides for automatic alignment of this critical parameter in a test system, with the DVB-T Test Receiver R&S EFA measuring CARRIER SUPPRESSION directly in magnitude and phase. The I and Q DC offsets can thus be optimized in a software calibration loop by means of R&S WinIQSim™ and R&S AMIQ, ensuring that your products offer residual carrier suppression better than the stipulated value.

3 Example of an impulsive noise measurement

Trial measurements have shown that test receivers are very sensitive to impulsive noise. The following example demonstrates this by means of a typical measurement on a DVB-T signal.

As already mentioned, the DVBTBN software calculates the interference signal. The corresponding time-domain signal (Fig. 9) is checked by R&S WinIQSim™. The impulsive noise signal is then transferred to the R&S AMIQ, which simulates the interference.

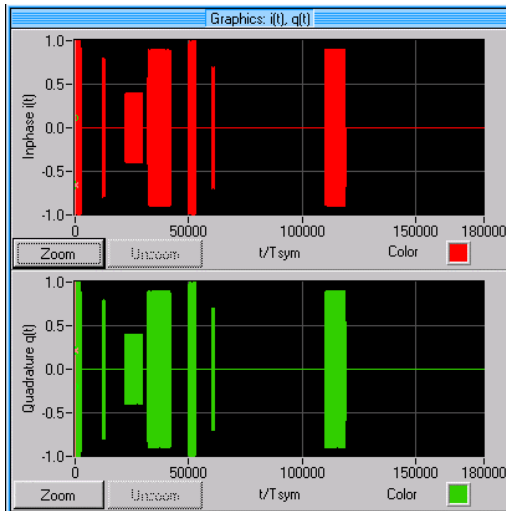

Fig. 9 Example of a Time-domain signal of impulsive noise

Settings on the R&S SFQ:

Modulation	DVB-T
Level	+3 dBm (yielding a reading of -3 dBm for the DVB-T signal on the R&S EFA)
C/N	OFF
Fading	OFF
Data	NULL PRBS packet
COFDM mode	474 MHz, 8k, guard interval 1/4, code rate 3/4

The maximum possible amplitude of the impulsive noise signal is determined by reading the BER before and after Viterbi: With a peak amplitude of 0.085 V at the I/Q outputs of the R&S AMIQ, the test receiver displays a BER of $2 \cdot 10^{-3}$ before Viterbi and a BER of $2 \cdot 10^{-4}$ after Viterbi (Fig. 10). This represents the limit of quasi-error-free (QEF)

operation. It corresponds to a ratio of -15.4 dB of the interference signal (peak) to the useful signal referenced to $V_p = 0.5$ V.

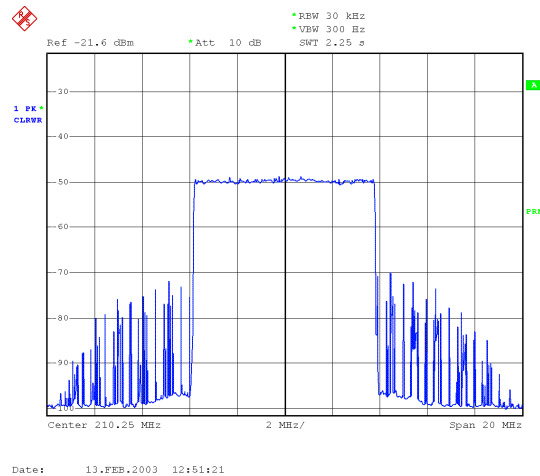

Fig.10 Impulsive Noise and DVB-T spectrum with BER = $2 \cdot 10^{-4}$ after Viterbi.

The I/Q baseband signal generated by the DTV Test Transmitter R&S SFQ has a peak voltage of 0.5 V. The 50 Ω 6 dB power dividers reduce the amplitude to 0.25 V. The total permissible peak voltage at the I/Q modulator input is 0.5 V, so a peak voltage of max. 0.5 V is also allowed at the I/Q outputs of the R&S AMIQ.

In the above example, the safety margin for the peak amplitude of the impulsive noise signal is $0.500 \text{ V} - 0.057 \text{ V} = 0.443 \text{ V}$, which is more than adequate for EMC measurements on set-top boxes.

The noise floor has no influence to BER because the C/N value of appr. 50 dB (see Fig.11, 12, 13) is in any case high enough for all measurements.

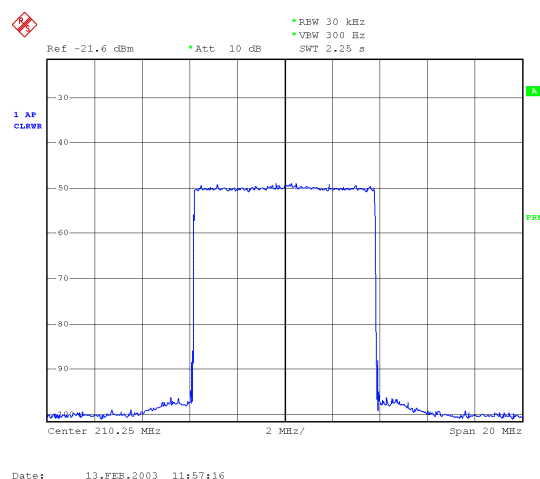

Fig. 11 Noise floor at 50 dB of test transmitter's DVB-T spectrum

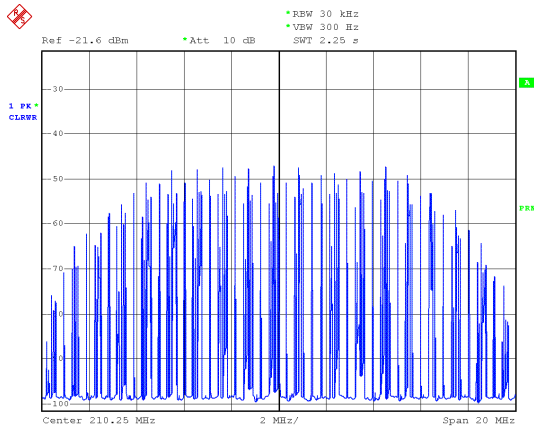

Fig. 12 Example: spectrum of impulsive noise at max. power

This example shows that also the bandwidth of the superposed impulsive noise is high enough. It covers more than the useful DVB-T spectrum.

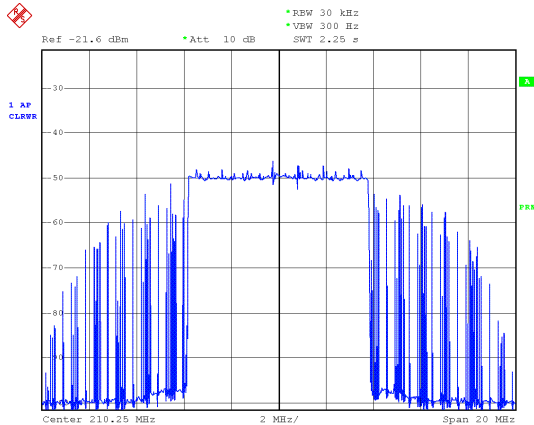

Fig. 13 Noise floor at 50 dB of DVB-T spectrum with superposed impulsive noise (max.power) at 50 dB

Figure 11 proves, that the influence to C/N is negligible with superposing impulsive noise using the proposed test setup. As all the values of C/N are in the range of 50 dB and measurable changings of the BER occur approximately at C/N < 30 dB the setup has high system reserve.

If the dynamic range of the impulsive noise is not high enough, it may be increased by 10 dB more. 10 dB attenuators between the I/Q outputs of the test transmitter and the power splitters as shown in Fig. 14 will fulfill this requirement. The noise floor generated by the test transmitter is only increased by appr. 4 dB and stays at a value

around 46 dB as shown in figure 14. The power of the DVB-T spectrum is decreased by other 10 dB in addition to the 6 dB effected by the 6 dB power dividers, but for tests on STBs it should be sufficient. Let's suppose the maximum DVB-T power is + 6.5 dBm the resulting power will be +0.5 dBm respectively -9.5 dBm with the high dynamic range as shown in figure 15.

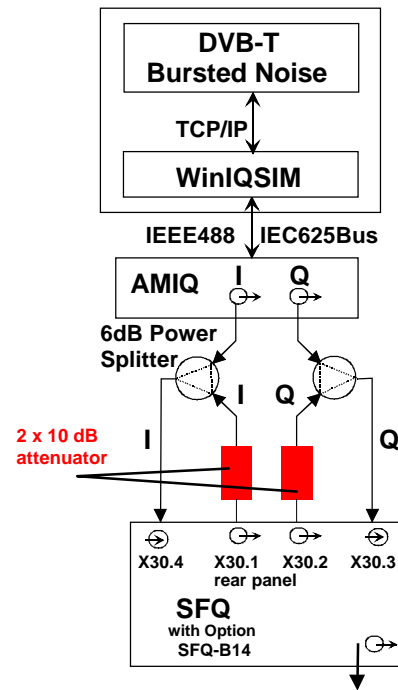

Fig. 14 Increasing the dynamic range of Impulsive Noise

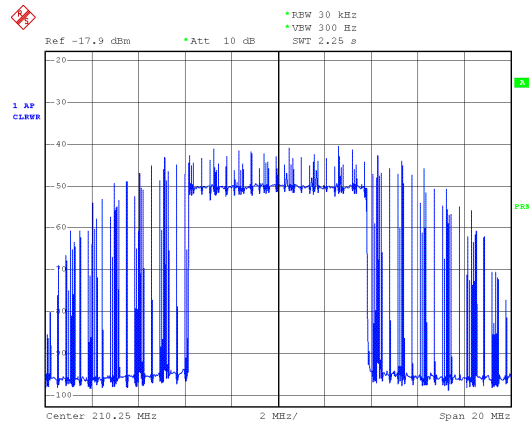

Fig. 15 Noise floor at 46 dB of DVB-T spectrum with superposed impulsive noise and extended dynamic range

The impulsive noise peaks are now about 10 dB higher than the DVB-T spectrum. As the sensitivity of a STB to impulsive noise is high, as shown in figure 10, this high power impulsive noise will nearly never be necessary.

4 Conclusion

The test setup described in this contribution for the first time enables the simple, reproducible, highly flexible and favourably priced generation of impulsive noise signals for test and acceptance test applications. The future will show what limit values are required for impulsive noise on DTV equipment.